



Light Traction Bloc Batteries

G06-06-180

(6V 180Ah @ 5hr)

Eternity Technologies valve regulated lead-acid batteries for the light traction market. With an innovative Gel-technology and maintenance free design, Eternity Technology Gel Bloc batteries are compatible with all universal cyclic applications.

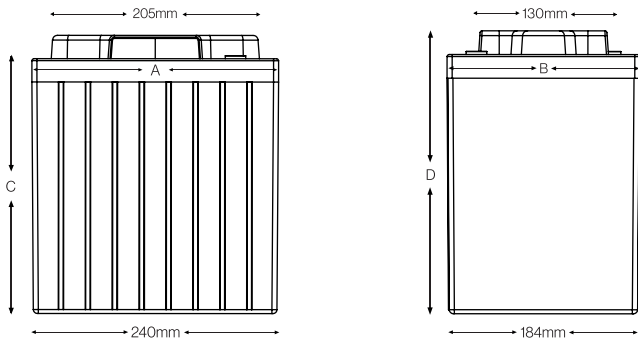

Electrical Specifications

Voltage	6V
80% DOD Voltage Cutoff	5.6V
Self Discharge	Less than 3% per month (20C/68°F)
Charge Temperature	Min: -10°C (14°F) / Max: 50°C (122°F)
Discharge Temperature**	Min: -40°C (-40°F) / Max: 50°C (122°F)
Storage	Min: -20°C (-4°F) / Max: 60°C (140°F)

Amp Hours (AH)					
20 HR	10 HR	5 HR	3 HR	2 HR	1 HR
210	198	180	166	156	126

** CAUTION: Depths of discharge, operating voltages and currents, when designing systems for use at maximum temperatures, will vary.

Mechanical Specifications

Industry Reference	-	
Length (A)	9.6 in	243 mm
Width (B)	7.4 in	187 mm
Height (C)	9.9 in	251 mm
Height (D)*	10.8 in	274 mm
Weight	72 lbs	33 kgs
Terminal (Opt'l)	M8	
Cell(s)	3	
Electrolyte	Gel	
Terminal Torque Nm	8	

NOTE: There is a tolerance of +/-2%.

* Including A-Terminal

B Part of our Bloc Batteries range

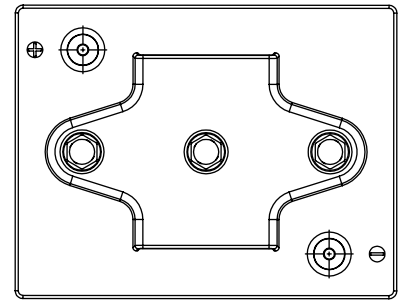

Features

Maintenance-free bloc batteries in Gel technology (no topping up during lifetime)

Good high current performance for extreme operating conditions

High-class patented safety valve

700 cycles (DIN EN 60254-1) (IEC 254-1)

Valve-regulated lead-acid battery

Recyclable

Long cycle life

Classified as a non-spillable battery is not restricted for transportation by:

- Air (IATA/ICAO provision 67)
- Ground (STB, DOT-CFR-HMR49)
- Water (IMDG amendment 27)

Applications

Electric vehicles

Wheelchairs

Cleaning machines

Electric working platforms

Universal for multiple cyclic applications

Compliant with EN60254-1 & IEC254-1

Charging profile

IU Charging $I = \text{min. } 12\% C_5 \text{ max. } 18\% C_5$
 $U = 2.4 \text{ V per cell}$

IUI Charging $I_1 = \text{min. } 12\% C_5 \text{ max. } 18\% C_5$
 $U = 2.35 \text{ V per cell}$
 $I_2 = 1.5\% C_5 \text{ for max. } 4 \text{ hours}$

Consigliamo i caricabatterie della nostra serie ZHF; per corretto dimensionamento con relativa taratura interfacciarsi con UBS.
 We recommend our ZHF series charger; contact UBS for the suitable charge cycle.

Self discharge at different temperatures

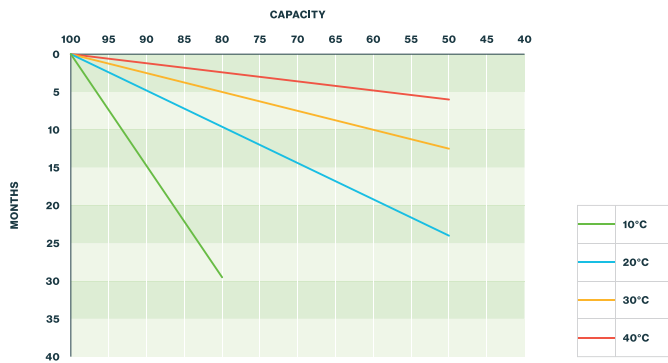

Capacity vs. temperature

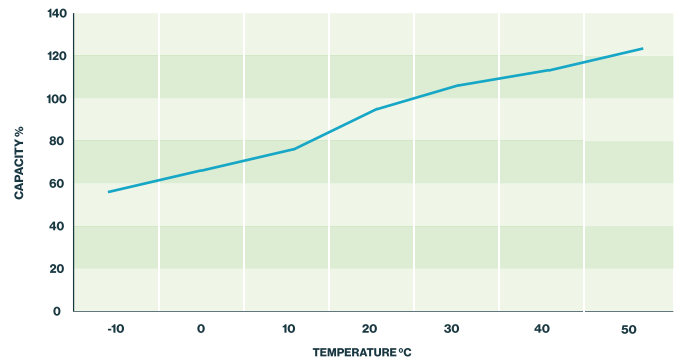

Relation between charging, voltage and temperature

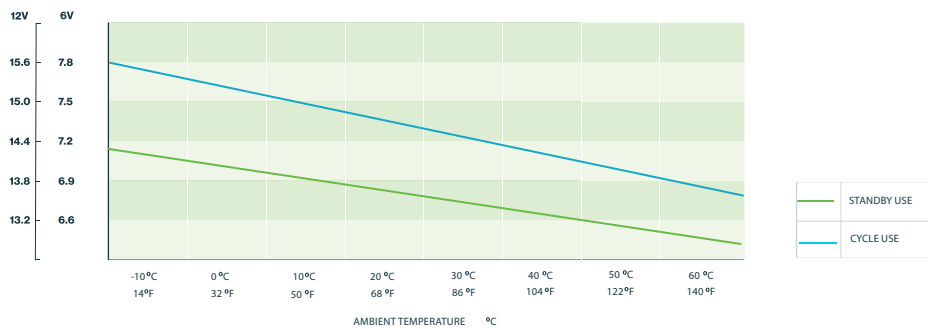

Storage: Determine the state of charge

